

**Drop-In**  
**Drop-in refrigerated well, static with fan**  
**(2 GN container capacity) and A**  
**overshelf**

ITEM # \_\_\_\_\_

MODEL # \_\_\_\_\_

NAME # \_\_\_\_\_

SIS # \_\_\_\_\_

AIA # \_\_\_\_\_

**341174 (D11C20)**

 Drop-in Refrigerated Well,  
 static with fan (2 GN  
 container capacity) with one  
 A type overshelf and LED  
 light

### Short Form Specification

**Item No.** \_\_\_\_\_

Hydrocarbon refrigerant gas R290 for the lowest environmental impact (GWP=3) - CFC and HCFC free. Designed to serve the food in gastrorm containers. Well in 304 AISI stainless steel with rounded corners to facilitate cleaning operations. The well is also equipped with a drain hole. Automatic defrosting guarantees evaporators clearance and efficient well cooling. High-density expanded polyurethane foam with cyclopentane guarantees excellent well insulation to reduce energy dispersion. A constant flow of cold air circulating through the containers guarantees the correct food temperatures. Temperature uniformity and fast cool down times are guaranteed thanks to powerful radial booster fans. Cylindrical stainless steel air diffusors provides a constant air circulation. 84% faster cool down time (than static refrigerated well) reduces energy consumption by allowing the operator to switch the machines on only when needed. The bottom is equipped with copper tubes to ensure proper cooling, with this system the air touches the cold surface and gets cooled. Then cooled air is being distributed with radial booster fans. Stylish A type overshelf designed for extra increased visibility on the surface for charming food display. Overshelf equipped with LED lights.

### Main Features

- Suitable for GN 1/1 containers with a maximum height of 150 mm.
- CB and CE certified by a third party notified body.
- Designed to serve the food in gastrorm containers.
- Precise temperature control and setting at 0,1°C .
- As standard the product comes with digitally controlled thermostat which is in line of HACCP norms and provides visual alarm as a warning of the increasing or decreasing temperatures.
- Food introduced at the correct temperature maintains its core temperature according to Afnor Standards.
- Automatic defrosting guarantees evaporators clearance and efficient well cooling.
- A constant flow of cold air circulating through the containers guarantees the correct food temperatures. Temperature uniformity and fast cool down times are guaranteed thanks to powerful radial booster fans. Cylindrical stainless steel air diffusors provides a constant air circulation.
- Stylish A type overshelf designed for extra increased visibility on the surface for charming food display.
- Overshelf equipped with LED lights.
- Designed to be positioned in flush installation providing improved cleanability and suitable for modern design installations.

### Construction

- Well bottom is inclined to facilitate water drainage.
- Well in 304 AISI stainless steel with rounded corners to facilitate cleaning operations. The well is also equipped with a drain hole.
- Electronic control with temperature display.
- IPx2 water protection.
- The bottom is equipped with copper tubes to ensure proper cooling, with this system the air touches the cold surface and gets cooled. Then cooled air is being distributed with radial booster fans.

**APPROVAL:** \_\_\_\_\_

- Overshelf in complete AISI 304.

## Sustainability



- Hydrocarbon refrigerant gas R290 for the lowest environmental impact (GWP=3) - CFC and HCFC free.
- High-density expanded polyurethane foam with cyclopentane guarantees excellent well insulation to reduce energy dispersion.
- 84% faster cool down time (than static refrigerated well) reduces energy consumption by allowing the operator to switch the machines on only when needed.

Front

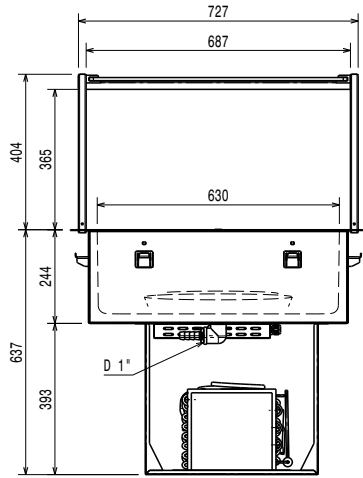

Side

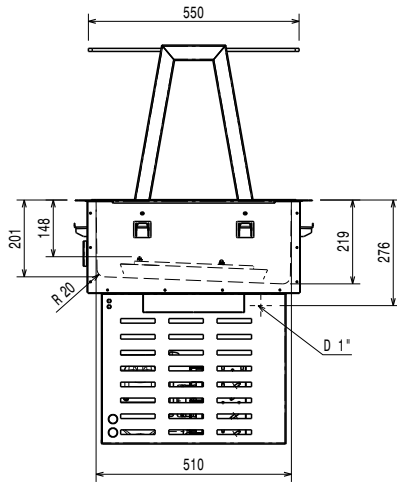

EI = Electrical inlet (power)

Top

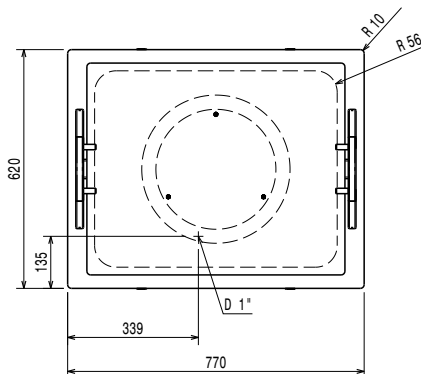

### Electric

#### Supply voltage:

341174 (D11C2O) 220-240 V/1N ph/50 Hz

#### Electrical power max.:

0.47 kW

### Water:

#### Water drain outlet size:

### Key Information:

External dimensions, Width: 770 mm

External dimensions, Depth: 620 mm

External dimensions, Height: 999 mm

Net weight: 59.46 kg

Shipping weight: 78 kg

Shipping height: 1320 mm

Shipping width: 670 mm

Shipping depth: 810 mm

 Shipping volume: 0.72 m<sup>3</sup>

Set temperature: -10 / 0 °C

### Refrigeration Data

Refrigerant type: R290

### Sustainability

Noise level: 62 dBA

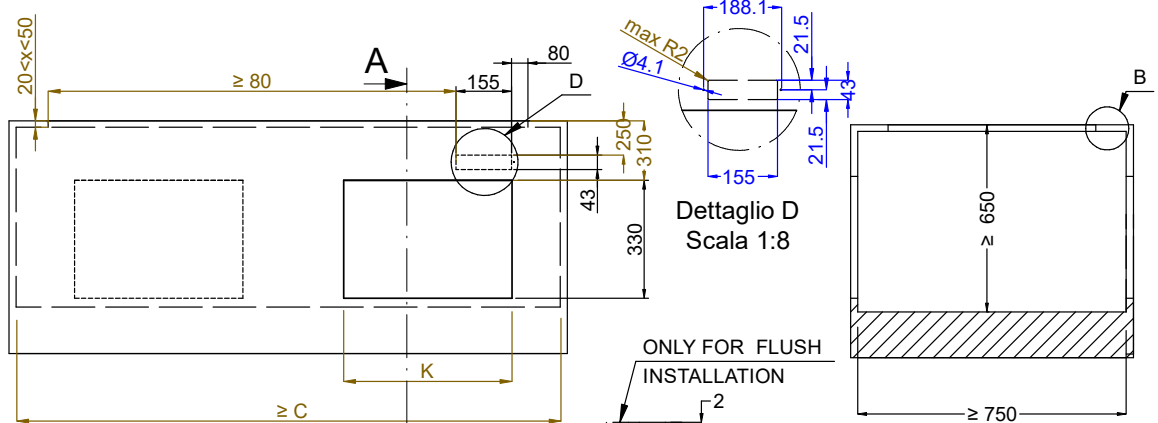

**Front view**  
Scala: 1:20

**Section Cut A-A**  
Scala: 1:20

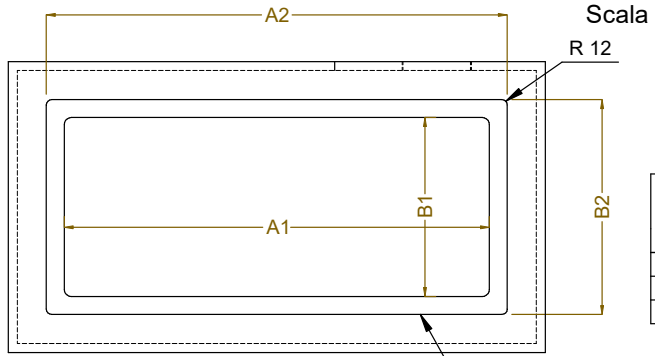

**Top view**  
Scala: 1:20

CAPACITY	CUTOUT		LOWERING FOR FLUSH INSTALLATION		C	K
	A1	B1	A2	B2		
2GN	740	580	774	624	880	470
3GN	1070		1104		1200	
4GN	1390		1424		1530	

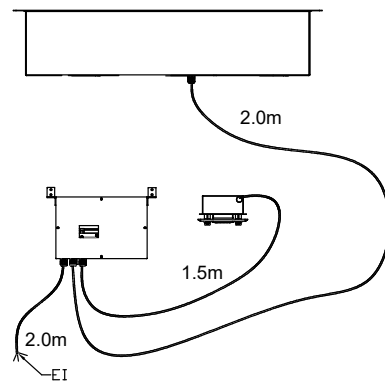
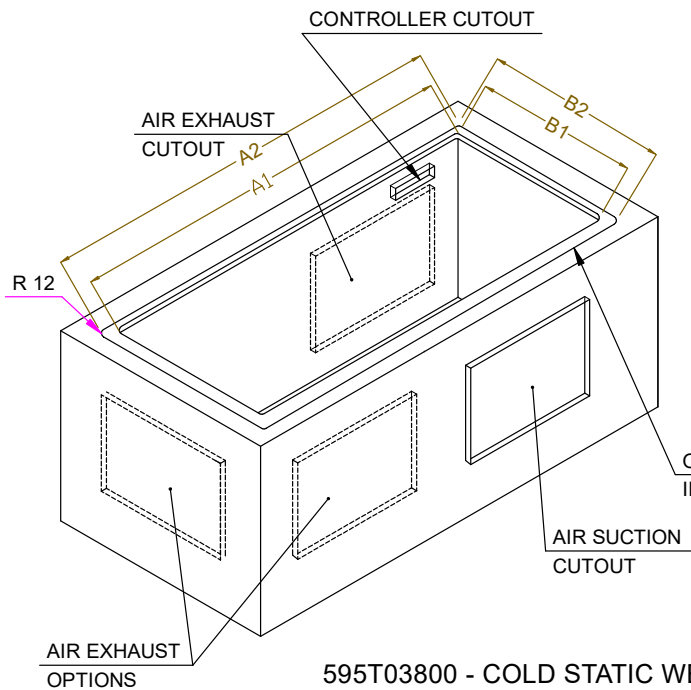

**595T03800 - COLD STATIC WELL WITH FAN OVERSH. ON THE FRAME**